

Replacement Guide

WINDOWS • DOORS
Andersen® 

For Handle Side Z-bar on Fullview Doors with Laminated Glass and Multi-Point Locking System

IMPORTANT: READ ENTIRE GUIDE BEFORE BEGINNING INSTALLATION.

PLEASE NOTE: Proper assembly, installation and maintenance are essential if the benefits of your Andersen® product are to be fully attained. Therefore, please read and follow this Replacement Guide completely. If your abilities do not match this procedure's requirements, contact an experienced contractor.

You may direct any questions to the **Solution Center** at 1-800-933-3626, Monday through Friday, 7 a.m. to 7 p.m. Central Time, and Saturday and Sunday, 8 a.m. to 5 p.m. Central Time.

 **WARNING:**

Improper use of hand or power tools could result in personal injury and/or product damage. Follow equipment manufacturer's instructions for safe operation. Always wear safety glasses.

 **WARNING:**

Weight of window and door unit(s) and accessories will vary. Use a reasonable number of people with sufficient strength to lift, carry, and install window and door unit(s) and accessories. Always use appropriate lifting techniques.

RECOMMENDED TOOLS:

- | | | | |
|--------------------------|----------------|-----------------------------|-------------------------|
| — Safety Glasses | — Pencil | — Tape Measure | — Drill |
| — 3/32" & 1/8" Drill Bit | — Center Punch | — Phillips Head Screwdriver | — Flat Head Screwdriver |
| — Hacksaw | — Chisel | — Tape | — Hammer |

1. OPEN DOOR AND SECURE:

- A. Open the door and set the closers to hold the door open.



2. REMOVE SCREW COVER:

- A. Remove the handle side Z-bar screw cover by prying up the edge with a flat head screwdriver and peeling the screw cover from the screw cover track.
- B. Properly dispose of screw cover. A new screw cover is provided in your replacement kit.

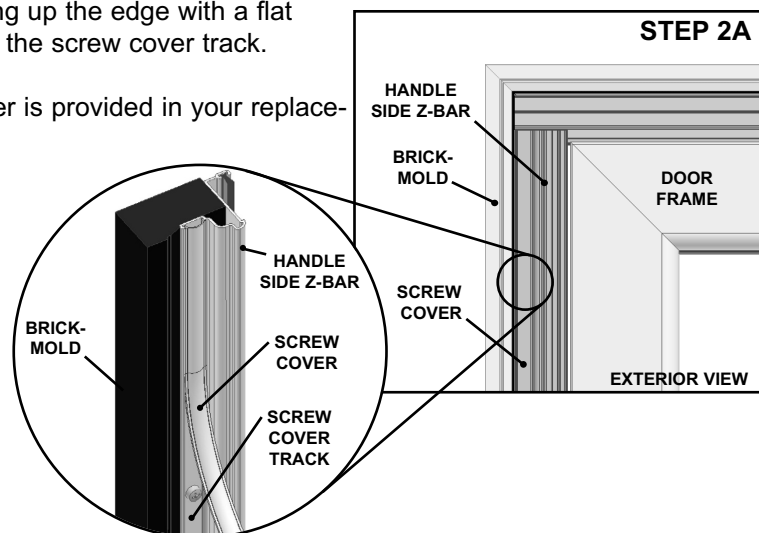

3. REMOVE STRIKER PLATES:

- A. Remove the three (3) striker plates from the handle side Z-bar by removing the eight (8) screws that attach the striker plates to the Z-bar. **Be sure to save the screws for later use.**
- B. Set the striker plates and screws aside to be reinstalled on replacement handle side Z-bar.

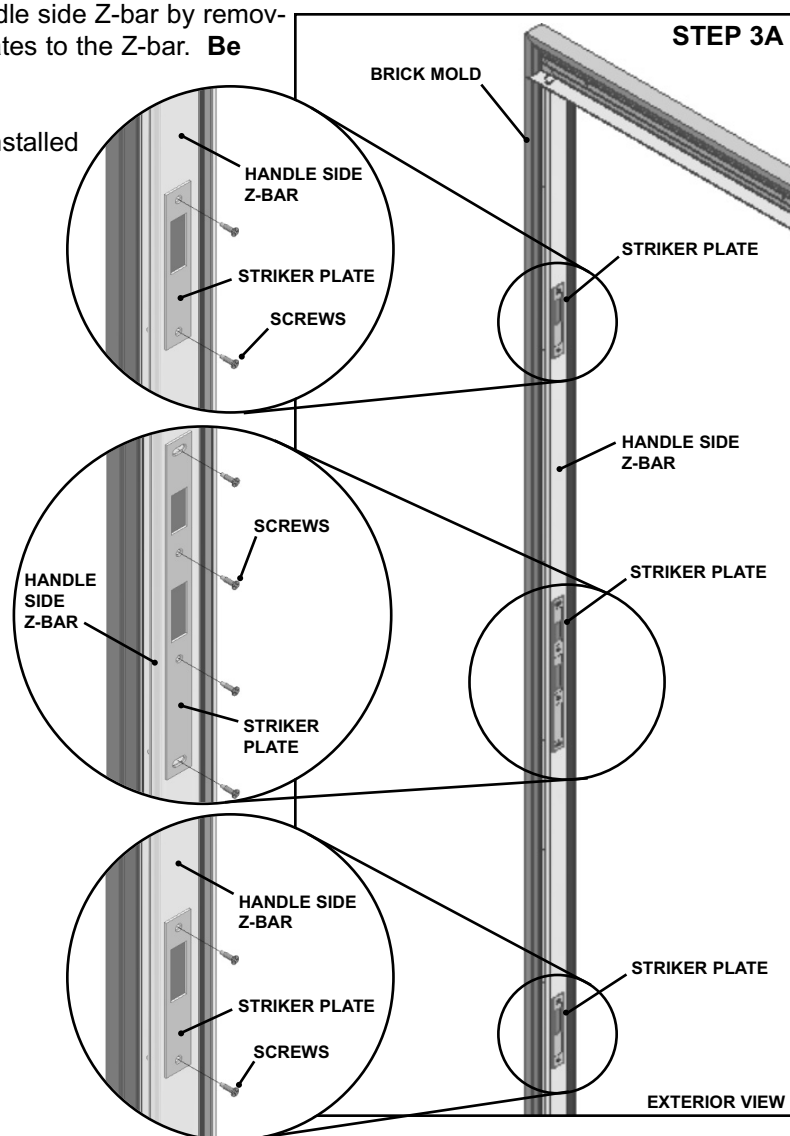

4. REMOVE HANDLE SIDE Z-BAR:

- A. Remove the handle side Z-bar from the door by removing seven (7) screws attaching the handle size Z-bar to the brickmold.
- B. Properly dispose of Z-bar and screws. A new Z-bar and screws are provided in your replacement kit.

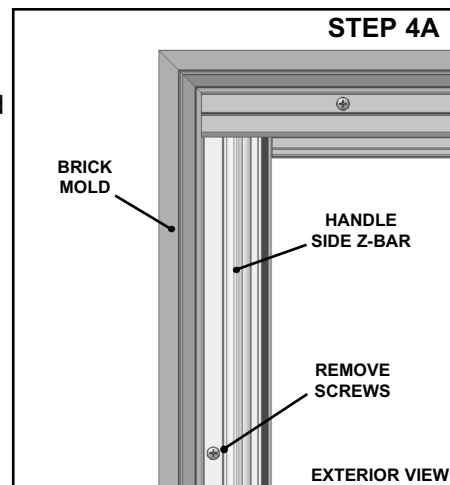

5. CUT AND INSTALL REPLACEMENT HANDLE SIDE Z-BAR:

- A. To determine which end of the handle side Z-bar is top, hold handle side Z-bar up to door opening opposite hinge side Z-bar. The weatherstripping will face the door opening. Mark top of handle side Z-bar with tape for future reference.

IMPORTANT

Mark top of handle side Z-bar with tape to help identify later in the installation. Cut to length at bottom.

- B. The handle side Z-bar will need to be cut to the handle side opening door height. To do so, measure the door opening height on the handle side from the underside of rain cap to top of door sill.

Hinge Side Door Opening Height _____

- C. Using this measurement, measure down from top of handle side Z-bar and mark a cutting line.

Note: If your entryway sill has an angled slope, you may wish to cut Z-bar at a slight angle to match.

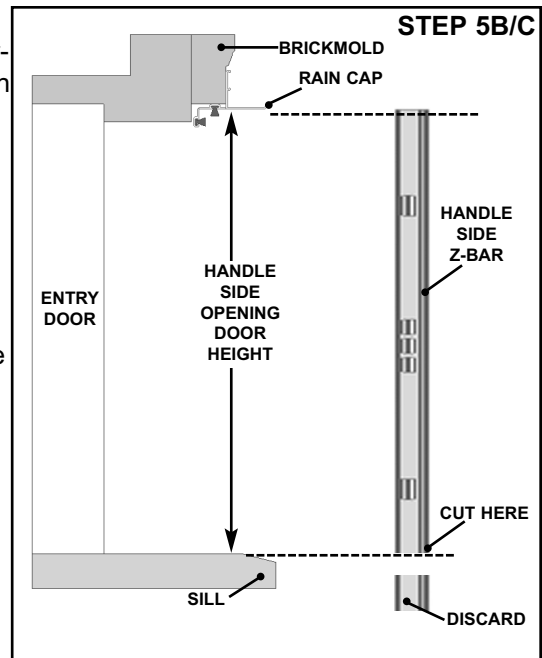

- D. Set handle side Z-bar in door opening so the top is pushed against underside of rain cap. Maintain a consistent 3/16" gap (shimming is optional) between handle side Z-bar (adjust Z-bar as needed) and side edge of door.

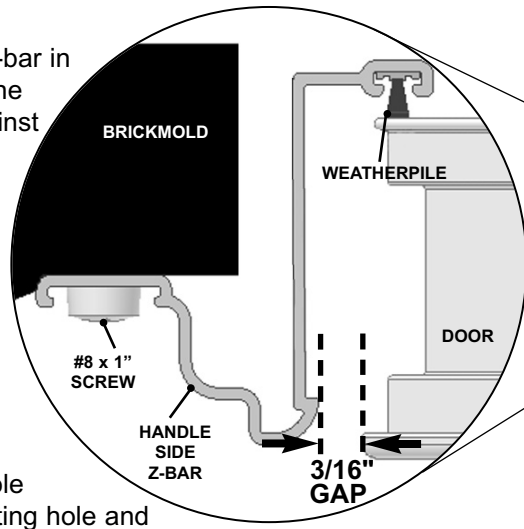

- E. Drill a 1/8" pilot hole through top mounting hole and into brickmold.

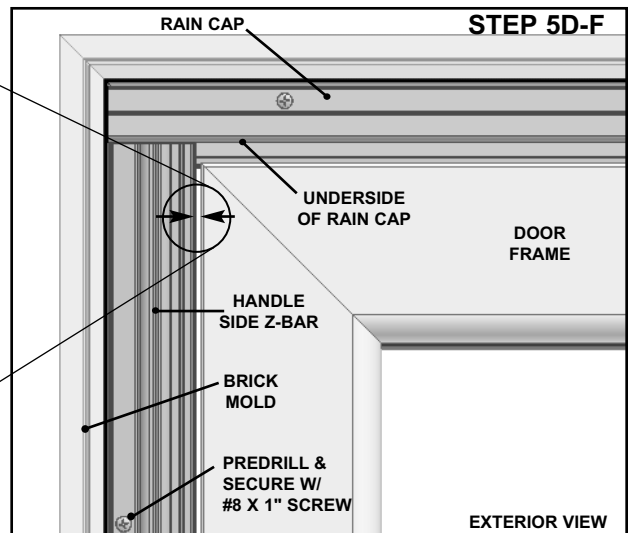

- F. Secure top of the handle side Z-bar with one (1) #8 x 1" screw. Re-check to make sure you have maintained the 3/16" gap and drill 1/8" pilot holes through the remaining mounting holes. Install the remaining six (6) #8 x 1" screws.

6. INSTALL HANDLE STRIKER PLATE:

- A. Extend the deadbolt and close the door. With a pencil, mark the top and bottom locations of the deadbolt and latch bolt on the Z-bar.
- B. Open the door and place the handle striker plate on the Z-bar. Center the top and bottom striker openings with the deadbolt and latch bolt marks on the Z-bar. Center the openings in the striker horizontally over the openings in the Z-bar. Mark the center of the two (2) slotted mounting holes with a pencil and remove the striker plate. Center punch and drill a 3/32" hole at each location marked.
- C. Place the handle striker plate on the Z-bar and secure with two (2) #6 x 1/2" screws.

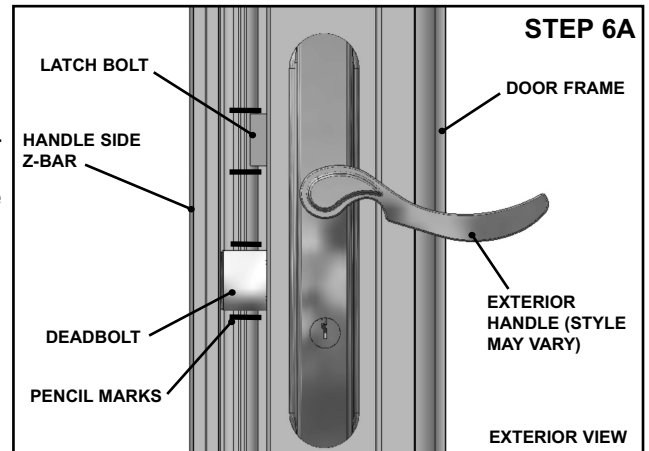

- D. Check the latch and deadbolt for proper function. Turn the thumbturn on the interior of the door. If the deadbolt makes contact with the primary door jamb, **even slightly**, chisel a recess into the door jamb. Chisel the recess deep and wide enough to provide adequate clearance for the deadbolt.

⚠ CAUTION

Chisel the recess deep and wide enough to provide adequate clearance for the deadbolt. Failure to do so may result in the deadbolt becoming lodged in the door jamb.

- E. If necessary, adjust the handle striker plate forward or back until the door latches properly. Make sure that the handle striker plate screws are tightened. Center punch and drill two (2) 3/32" holes through the remaining two (2) mounting holes. Install two (2) #6 x 1/2" screws into the round holes of the striker plate.

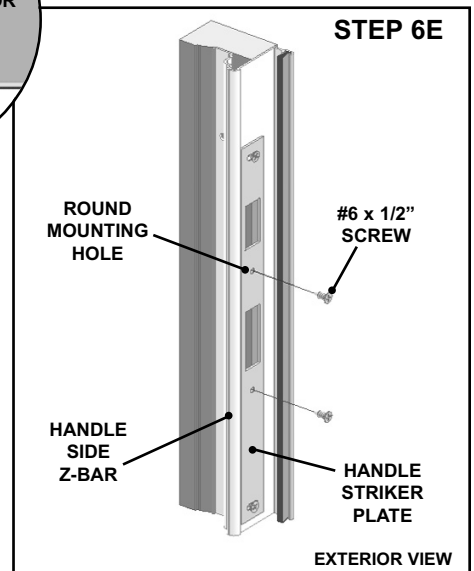
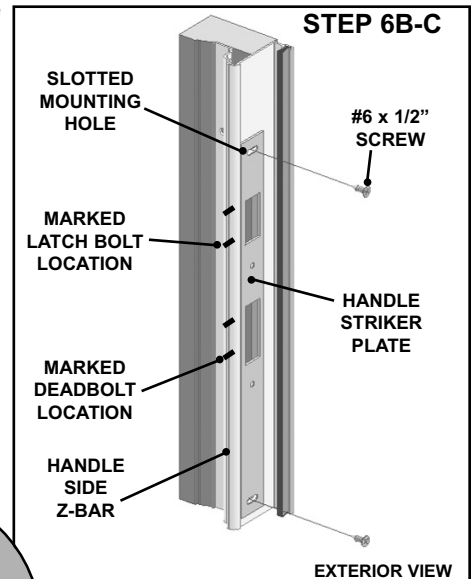
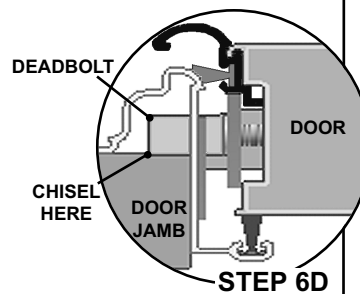

7. INSTALL TOP AND BOTTOM STRIKER PLATES:

- A. Extend the hook locks and close the door. With a pencil, mark the top and bottom location of the top hook lock on the Z-bar.
- B. Open the door and place the top striker plate on the Z-bar. Center the striker plate opening on the marks on the Z-bar. Center the openings in the striker plate horizontally over the opening in the Z-bar. Mark the center of the two (2) round mounting holes and remove the striker plate. Center punch and drill a 3/32" hole at each location marked.
- C. Place the top striker plate on the Z-bar and secure with two (2) #6 x 1/2" screws.
- D. Repeat steps A-C for bottom hook lock.
- E. Check the hook locks for proper function. If the hook locks make contact with the primary door jamb, **even slightly**, chisel a recess into the door jamb. Chisel the recess deep and wide enough to provide adequate clearance for the hook locks.

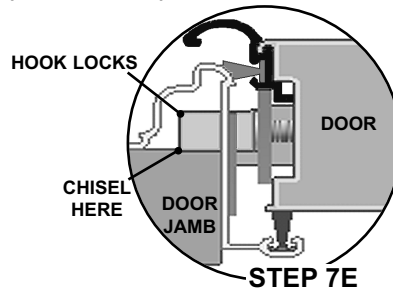
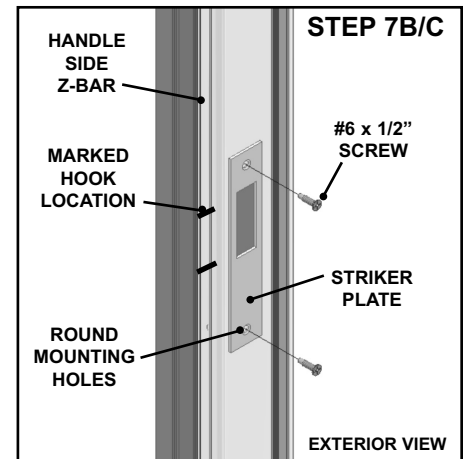
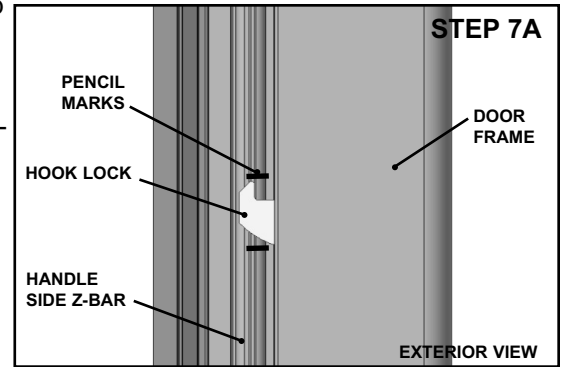

8. INSTALL SCREW COVER:

- A: Locate the handle side Z-bar screw track.
- B: Lock one leg of screw cover in notch of screw track. Use fore-fingers to apply pressure to other leg to snap it into the track. Make sure that the screw covers snap into the screw track along the entire length of the Z-bar.
- C: Making sure that the screw cover is flush with the top of the Z-bar, trim off any excess at the bottom of the Z-bar with a utility knife.

